



Installation Instructions

ThermCABLE

ThermCABLE is suitable for a wide range of floor coverings – ceramic, slate, terracotta, porcelain, marble, stone or limestone. A ThermCABLE electrical underfloor heating system is designed for installation directly under these floor coverings and the following instructions should be read carefully before you begin your installation.

For vinyl, carpet or laminate floors first check with the manufacturer that it is suitable for underfloor heating. ThermFloor will offer responsible advice on these applications with regard to flexible floor screeds or self levelling compound over the heat source. Please call 0845 644 3632.

Please read these instructions in conjunction with the Guarantee Card enclosed with your ThermFloor heating system.

The best subfloors for applying ThermCABLE are tile backer boards (insulation construction boards), concrete, WBP plywood (weather & boil proof plywood) and existing old tile surfaces. There is no need to prime the surface of ThermBOARD tile backer board since it already has good quality construction properties comprising a cement polymer mortar finish on both sides of the board.

If the subfloor is asphalt or bitumen it must be either removed or a layer of insulation backer board applied over the floor as a barrier.

Electrical Requirements

It is recommended the installation is carried out in accordance with local electrical regulations and the wiring of the system to the mains electrical supply is performed by a qualified electrician.

The heating system is designed for operation at 230V 50Hz.

All installations require an RCD (residual current device) for safe operation.

We recommend the heating is connected to a dedicated circuit to reduce interference between appliances. If connecting to an existing circuit, make sure the total current (amps) of all ThermCABLE and other appliances connected to the circuit do not exceed the current capacity of the circuit – always consult your electrician.

Part Number	Cable Length (m)	Floor Area (m ²)				Total Watts	Total Cable Resistance (Ohms)
		100w/m ² (100mm spacing)	120w/m ² (82mm spacing)	160w/m ² (62mm spacing)	200w/m ² (50mm spacing)		
10CABLE18	18	1.80	1.50	1.13	0.90	180	294
10CABLE24	24	2.40	2.00	1.50	1.20	240	220
10CABLE36	36	3.60	3.00	2.25	1.80	360	147
10CABLE60	60	6.00	5.00	3.75	3.00	600	88
10CABLE84	84	8.40	7.00	5.25	4.20	840	63

You can combine more than one reel of ThermCABLE to cover the total floor space. Each reel of ThermCABLE comes with a single 4m long cold lead wire and with multiple circuits the lead wires must be connected electrically in parallel.

ThermCABLE requires more time to install than ThermMAT but it can provide the installer with layout flexibility, especially in smaller areas with obstacles, such as en-suites, shower rooms and bathrooms. *ThermCABLE has the electrical supply lead at one end only making it easy to apply the cable on the floor with a uniform spacing between cable runs without the need to get two ends of cable back to a termination point.* **The above table provides a guide to floor area permutations at various watts density values and cable spacing.**

IMPORTANT: Before and during installation carry out continuity tests by measuring the cable resistance of the heating element. Also, measure the insulation resistance value as required by BS7671 - the minimum reading should be 10Megohms regardless of the element length.

- Perform both tests at each stage of the installation as recommended (i.e. before installing, immediately after installing and before putting the heating into operation).
- **Record the results on your guarantee card.**

ThermCABLE has been tested in accordance to National and International Standards for safety.

All cables comply with rules regarding the EMC (Electro Magnetic Compatability) and fulfil the ICNRIP guidelines and regulations with regards to EMF (Electro Magnetic Fields) and are suitable for use in any room.

The ThermCONTROL range of thermostats are rated at 16A – this will enable direct switching of loadings up to approx. 3600 watts. Higher loadings must be switched by a suitably rated contactor – or alternatively split the heating into more than one heating zone each operated by its own thermostat.

In bathrooms the thermostat control **MUST** be mounted outside the bathroom.

The heating cable must not be cut.

To facilitate installation it is possible to cut the 4m long cold lead wire to suit.

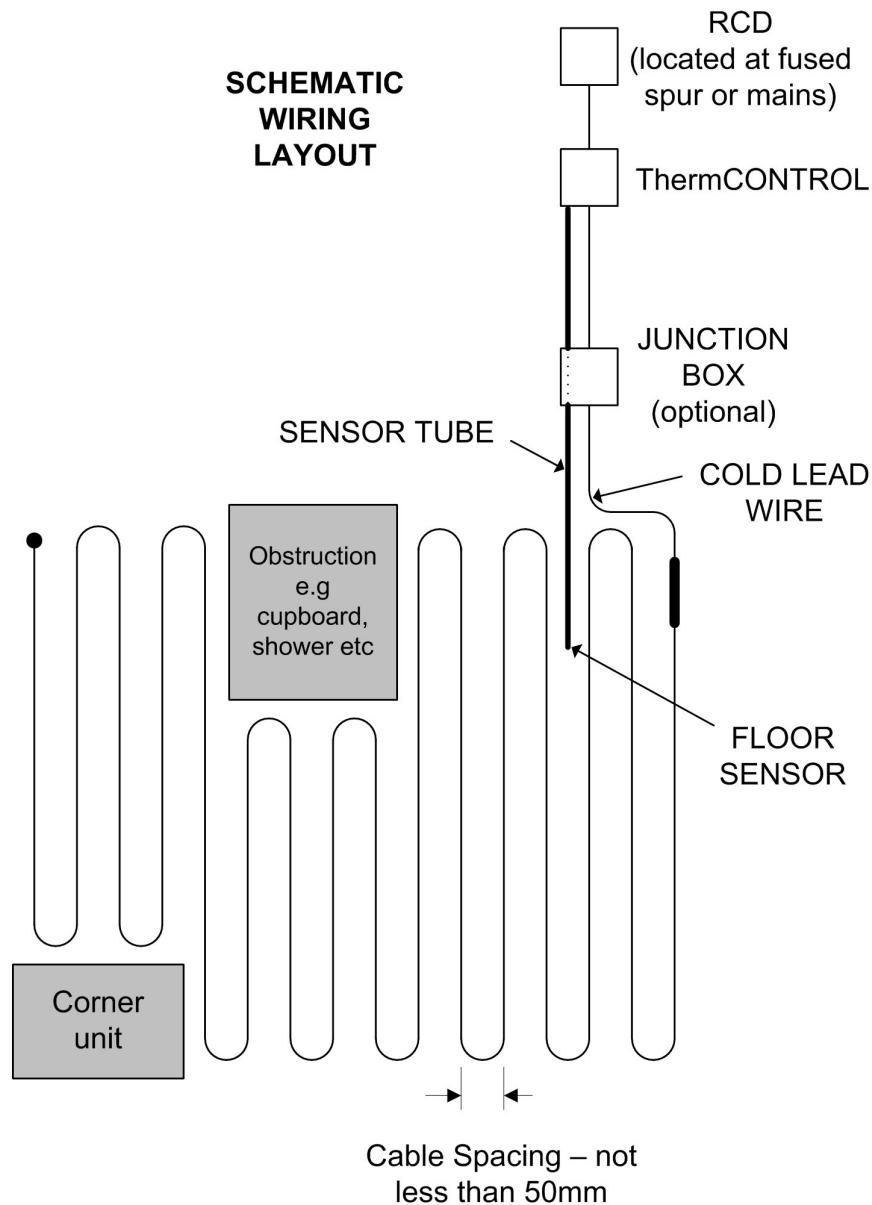

The above schematic is a basic configuration of the wiring requirements. The 230V electrical supply is provided from an RCD protected mains or via an RCD protected fused spur unit.

The above demonstrates the ability of ThermCABLE to be applied uniformly around obstructions.

Floor Preparation

Wooden Subfloors – timber floorboards, chipboard etc. Before proceeding with the installation make sure any loose boards and/or chipboard are firmly fixed and reinforce the floor if necessary to prevent any movement in the floor that could cause tiles to crack. The floor should be level.

Reinforcement can be performed by covering the complete floor with 18mm WBP plywood (weather & boilproof plywood).

When the floorboard or chipboard flooring has been firmly fixed and is considered to be level, an alternative to WBP plywood would be to cover the floor with ThermBOARD insulating backing board.

Concrete Subfloors – Before proceeding with the installation repair any imperfections in the floor and level the floor with approved building materials.

Wooden & Concrete Subfloors - Clean the floor surface so that it is free from dust, dirt, grease or oil marks.

Prime floors with a water based PVA adhesive primer to improve bonding between the adhesives and the subfloor.

Use a primer recommended by your tile/screed adhesive supplier. Any good tile, builder or hardware outlet will supply this inexpensive. You will be able to purchase the exact specification and quantity required for the floor area involved.

When installing ThermBOARD insulating backer boards use tile adhesive to fix the boards to concrete floors and galvanised screws/washers on wooden subfloors.



Opposite shows a floor prepared with a layer of insulating tile backer board.

First Step

Plan the installation.

Draw a general view of the room and mark the area which will be covered with heating elements. Avoid heating under units and sanitary ware as this can

cause heat blockage and it is unnecessary to heat these areas anyway.

Mark the location of the supply lead – the cold lead wire. See the schematic wiring layout for guidance.

Having decided on this position you can cut a groove in the floor to accommodate the protective floor sensor tube. The sensor must run centrally (in the middle) between two runs of heating element so it is important to note where the element will be positioned. The object is to make the sensor tube level with the heating element.

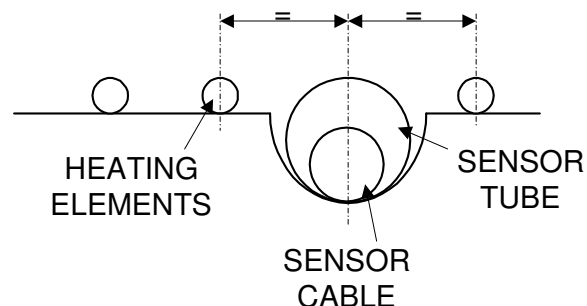

The sensor must not cross or touch the heating element.

Make sure the sensor tube has a gradual bend when it enters floor level - this will ensure the sensor cable can be easily inserted or withdrawn. The tube can be cut to length to suit. Seal the end of the tube with masking tape.

The cable joint between heating element (yellow cable) and cold lead wire (black cable) must be located on the floor. Ensure this joint also lies level with the heating system – another small groove may be necessary.

Cable Reel

Cable can be dispensed from the reel with ease. Do not remove the cable from the reel before fixing as it will make the installation difficult.

Floor Insulation

Heat travels in both directions, up and down, and without insulation in a concrete subfloor you can expect to lose up to 30% of the installed heat to absorption in the subfloor.

Whatever the subfloor material, wood or concrete, a thermal barrier between the heating element and subfloor will increase performance, heat up time and save electricity costs.

To make the best use of the installed energy, insulation should be installed, either below the subfloor or as a layer of backer board on top of the subfloor, OR BOTH.

Cable Spacing Calculation

This is quite simple but very important. All the cable must be used on the floor and the cable cannot be cut, crossed over or bunched together.

Firstly, work out the total free area where you will be applying the heat.

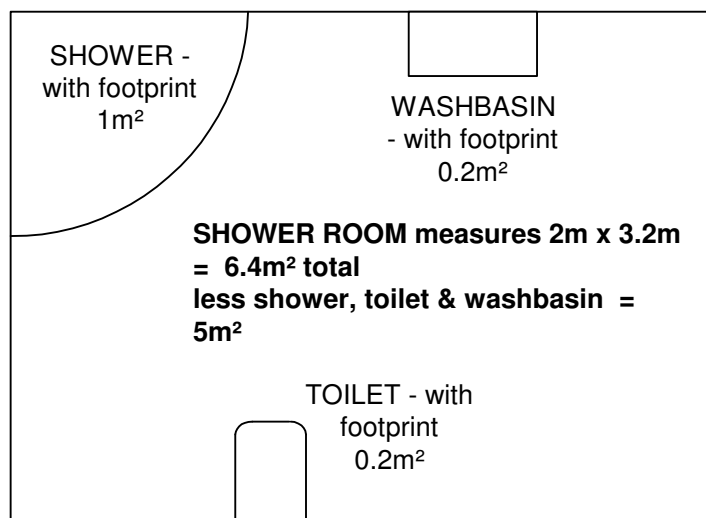

Allow a minimum 50mm unheated gap around the perimeter of the room.

In the above example, the free area is 5m² but we must now deduct the area occupied by the unheated gap around the perimeter – lets call this 0.5m²

The area to work with is $5 - 0.5 = 4.5\text{m}^2$

To calculate the cable spacing multiply the area to work with by 1000 and divide by the cable length.

This installation would suit ThermCABLE part number 10CABLE60, a 60 metre cable rated at 10w/m and total loading of 600 watts

$4.5 \times 1000 \div 60 = 75\text{mm spacing}$ (this spacing is referred to as the c-c distance)

The spacing is important and the installed loading can be estimated from the table provided. Should your calculation arrive at a spacing less than 50mm the cable size is too large – **Action:** select another cable size.

Testing

Remember to test the heating element at each stage recommended and record the readings on your guarantee card.

Please consult your electrician - electrical safety is paramount



The instrument opposite is a digital multimeter and the model shown is perfect for testing cable continuity and its resistance (ohms), as well as the resistance of the sensor cable.

However, this model of multimeter will not be capable of taking insulation resistance readings, which is a very important reading to record for all electrical installations.

Insulation resistance readings should also be carried out as required by BS7671.

When taking the measurement of insulation resistance it should give a minimum reading of 10megohms regardless of the heating element length.

Cable Layout & Fixing

Begin by marking the floor with a felt tip marker pen at intervals equal to the calculated spacing. Always consider the position you have chosen for the thermostat and sensor tube.

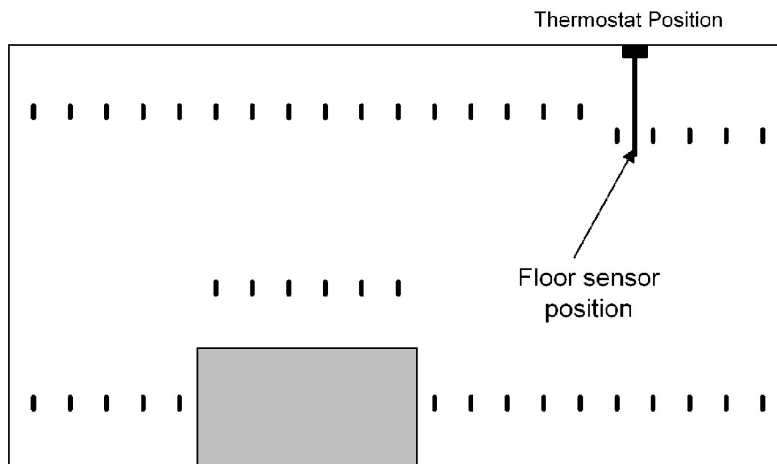

One of the most common methods of fixing a cable to the subfloor is to use fixing tape – a roll of fixing tape is included in every cable pack.

After marking out the spacing draw the cable from the reel and follow the chosen route so that it is applied with uniform spacing and the cable lines up with the markings.

Initially, secure with fixing tape in the corners of the room only, gradually working across the room and rolling the fixing tape out to hold the cable in position – see below.

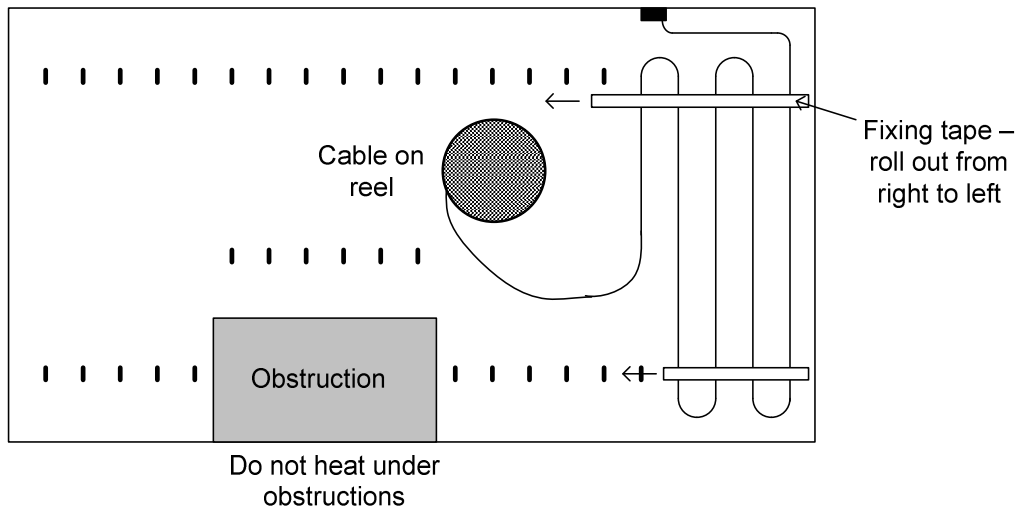

This will enable you to adjust the spacing where necessary so that the spacing is even, before applying the final fixings – see below.

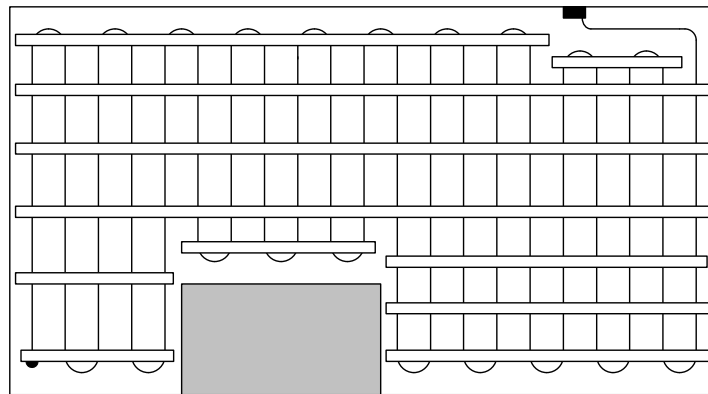

Using your hands, or even walking over the area in your stocking feet, apply light pressure overall to make sure the fixing tape is secured.

Tiling

The next stage is the fixing of the tiles. You can select a single step or two step method. Latex, acrylic or polymer based adhesives are acceptable.

Spread adhesives with a PLASTIC notched trowel to avoid damage to the heating element, taking care not to dislodge any of the heating cable from its fixed position.

Single Step: Using a flexible adhesive the tiling can be carried out as a single operation directly on top of the heating cable. Allow a depth of adhesive sufficient to lay the tile and encapsulate the heating element with no air gaps.

Two Steps: Apply a thin layer of flexible self levelling compound just sufficient to cover and encapsulate the heating elements with no air gaps. Allow to cure in accordance with the manufacturers instructions. This will provide protection to the heating cable prior to tiling. Then apply the tiles in flexible tile adhesive in the normal manner.

Both steps are approved for under tile heating.

All adhesives must be flexible and suitable for underfloor heating. These are available from any good tile, builder or hardware outlet and the outlet will provide full instructions on the application of the adhesives and screed materials.

Grouting

Use a **latex, acrylic or epoxy grout** for grouting between the tiles. Latex, acrylic and polymers add flexibility to grouts to resist cracking. Epoxy grouts provide high strength, good thermal shock resistance and fast cure. Do not use sharp objects to clean the grout from between the tiles. Most damage to the heating cable occurs when excess grout is scraped away and a sharp tool goes deep enough to cut the cable.

If in any doubt please contact ThermFloor for support – 0845 644 3632

Reminders

Do – read the instructions

Do - Use approved adhesives and floor screeds – consult your local tile or builders merchant outlet

Do - use the right size of cable and only apply the cable to the area to be heated

Do - consult a qualified electrician

Do - make sure the heating is connected to an RCD rated 30mA maximum.

Do - make sure the black joint between the yellow heating element and the black cold lead wire is in the floor beneath the tiles.

Do - keep a record of where the floor probe is positioned and the general layout of the heating cable for future reference.

Do Not - cut the heating element

Do Not - Allow heating element to touch or cross over itself.

Do Not - cut or prepare tiles on top of the heating cable

Support

a. ThermFloor deliver next day carriage free

b. You can send detailed drawings with dimensions and scale and we will send you a heating scheme by return.

c. Include your phone and fax numbers and email address.

d. Phone 0845 644 3632, fax 01772 761 222 or email sales@thermfloor.co.uk for Technical and Design advice and Commercial support

